



Features

- ◆ Modular PLC with pluggable / Independent display
- ◆ Flexible IO card selection
- ◆ Expandable via MODBUS Protocol
- ◆ RTC with time switch functions



Technical Specification

Display specifications

Type	LCD with green backlight & black font	7 Segment LED
Digits	2 lines x 8 characters (Font side 5x7mm)	1 Red
LED banks	---	6 Red LED
No. of keys	5 keys (4 User configurable)	1 key
No. of slots	4	

Input specifications

Digital input	
No. of inputs	4+1*
Input type	PNP
Input voltage range	5-30V
Response time	Depends on debounce time & ladder execution time
Debounce time	10ms
Fast input	
No. of inputs	1
Input type	PNP
Input frequency	5 kHz
Analog inputs	
No. of channels	1*
Analog type	Voltage
Range	0-10V
Resolution	12 bit
Conversion time	100ms
Accuracy	0.25%

* = 1 Digital input can be configured as analog input (0-10V)

Communication

Communication port	2 Ports ; Port 1 - RS485 slave, Port 2 - RS485 master
Communication protocol	MODBUS RTU
Connector type	2 Wire
Transmission type	Half duplex
Transmission speed	9600,19200, 38400, 57600, 115200 bps
Data bits	7 or 8
Parity	None, Odd, Even, Space, Mark
Stop bits	1 or 2

Functional specifications

Programming	Windows based software for ladder programming & HMI config
Timer operational modes	On delay, Off delay, Pulse, Special (Up / Down) Timer
Timer resolution	1ms (Only accurate 1ms timer block)
Counter	Up counter, Down counter, Up-Down counter, Special (Up-Down counter)
Other blocks	Analog input / output, Time switch, RTC etc
Memory retention	10 Years
RTC	Yes
Memory	
Data memory	32Kb
Code memory	240Kb
EPROM	8Kb
No. of objects	5000
Min. scan time	200usec
Typical scan time	1msec (Based on ladder programming)

Environmental specifications

Operating temperature	5 to 55°C
Storage temperature	-25 to 70°C
Humidity (Non condensing)	10 to 95%

Mechanical specifications

Mounting type	Rail mount
Weight	150 gms without IO cards

Supply specification

Supply voltage	90 to 270VAC (50/60Hz)	18 to 30VDC
Power consumption	6VA	6W
Sensor source	24V, 50mA	

Dimensions (All are in mm)

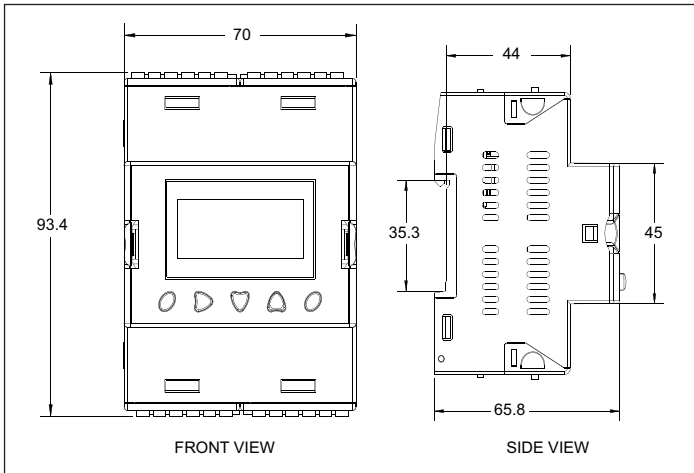

Terminal connection

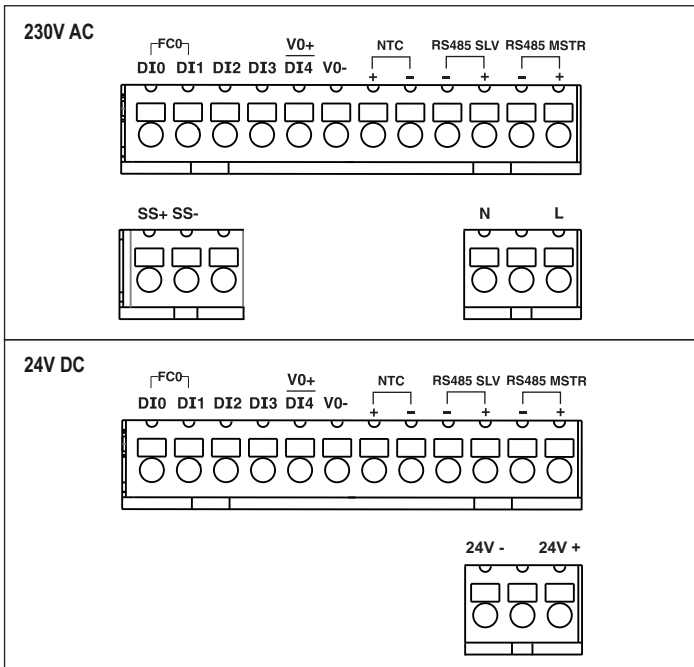

Ordering information

Product code	Description	Certification
MIBRX-4M-1-1-1-24VDC	MiBRX 4M Base module - 4 Slots, 5DI (incl 1FI, 1AI-V), NTC, RTC, Master	CE RoHS
MIBRX-4M-1-1-1-230V	MiBRX 4M Base module - 4 Slots, 5DI (incl 1FI, 1AI-V), NTC, RTC, Master	CE RoHS
MIBRX-4M-1-0-0-230V	MiBRX 4M Base module - 4 Slots, 5DI (incl 1FI, 1AI-V), NTC	CE RoHS
MIBRX-4M-1-0-0-24VDC	MiBRX 4M Base module - 4 Slots, 5DI (incl 1FI, 1AI-V), NTC	CE RoHS

Supported display modules

Display module	Description	Certification
MIBRX-DSP-4M-0-1-06-A	Integrated blind display for MIBRX 4M; Single digit 7seg, 6 LEDs for indication & 1 key	CE RoHS
MIBRX-DSP-4M-8-2-08-A	Integrated 8x2 character LCD Display with 5 keys for MIBRX 4M	CE RoHS
MIBRX-DSP-AP-4M	MiBRX 4M Adapter Plate for independent display	CE RoHS

Supported I/O cards

IO cards	Description	Certification
MiBRX-SC-DI04	MiBRX Slot Card - 4 Digital Inputs	CE RoHS
MiBRX-SC-DI04-ISO	MiBRX Slot Card - 4 Digital Inputs (Isolated)	CE RoHS
MiBRX-SC-DI06	MiBRX Slot Card - 6 Digital Inputs	CE RoHS
MiBRX-SC-DI06-AC	MiBRX Slot Card - 6 Digital inputs (AC)	CE RoHS
MiBRX-SC-DI06-ISO	MiBRX Slot Card - 6 Digital Inputs (Isolated)	CE RoHS
MiBRX-SC-RO03	MiBRX Slot Card - 3 Relay Outputs	CE RoHS
MiBRX-SC-RO04	MiBRX Slot Card - 4 Relay Outputs	CE RoHS
MiBRX-SC-RO04-12V	MiBRX Slot Card - 4 Relay Output (12V)	CE RoHS
MiBRX-SC-RO05	MiBRX Slot Card - 5 Relay Outputs (1.5 A)	CE RoHS
MiBRX-SC-TO04	MiBRX Slot Card - 4 Transistor Outputs	CE RoHS
MiBRX-SC-DI02-RO02	MiBRX Slot Card - 2 Digital Inputs & 2 Relay Outputs	CE RoHS
MiBRX-SC-DI02-RO03	MiBRX Slot Card - 2 Digital Inputs & 3 Relay Outputs	CE RoHS
MiBRX-SC-DI02-TO02	MiBRX Slot Card - 2 Digital Inputs & 2 Transistor Outputs	CE RoHS
MiBRX-SC-DI02-AI01-T	MiBRX Slot Card - 2 Digital Inputs & 1 Analog Input - TC/RTD	CE RoHS
MiBRX-SC-AI02-V	MiBRX Slot Card - 2 Analog Inputs - Voltage	CE RoHS
MiBRX-SC-AI02-V-ISO	MiBRX Slot Card - 2 Analog inputs - Current (Isolated)	CE RoHS
MiBRX-SC-AI02-I	MiBRX Slot Card - 2 Analog Inputs - Current	CE RoHS
MiBRX-SC-AI02-I-ISO	MiBRX Slot Card - 2 Analog inputs - Current (Isolated)	CE RoHS
MiBRX-SC-AI02-V-I	MiBRX Slot Card - 2 Analog Inputs - 1 Voltage & 1 Current	CE RoHS
MiBRX-SC-AI02-TC	MiBRX Slot Card - 2 Analog Inputs - Thermocouple	CE RoHS
MiBRX-SC-AI02-TC-ISO	MiBRX Slot Card - 2 Analog inputs - Thermocouple (Isolated)	CE RoHS
MiBRX-SC-AI02-RTD	MiBRX Slot Card - 2 Analog Inputs - RTD	CE RoHS
MiBRX-SC-AI02-RTD-ISO	MiBRX Slot Card - 2 Analog inputs - RTD (Isolated)	CE RoHS
MiBRX-SC-AI02-PT1000	MiBRX Slot Card - 2 Analog Inputs - Pt1000	CE RoHS
MiBRX-SC-AI02-PTC	MiBRX Slot Card - 2 Analog Inputs - PTC	CE RoHS
MiBRX-SC-AI02-NTC	MiBRX Slot Card - 2 Analog Inputs - NTC	CE RoHS
MiBRX-SC-AO01-V/I	MiBRX Slot Card - 1 Analog Output	CE RoHS
MiBRX-SC-AO02-V-I-ISO	MiBRX Slot Card - 2 Analog Outputs (Isolated)	CE RoHS
MiBRX-SC-FI02	MiBRX Slot Card - 2 Fast Inputs (10KHz)	CE RoHS
MiBRX-SC-FO01-TO01	MiBRX Slot Card - 1 Fast Output (10KHz) & 1 Transistor Output	CE RoHS
MiBRX-SC-LC02	MiBRX Slot Card - 2 Analog Inputs - Load Cell (24 Bit)	CE RoHS
MiBRX-SC-DL	MiBRX Slot Card - Datalogging (2MB) & RTC	CE RoHS
MiBRX-SC-WIFI	MiBRX Slot Card - WIFI	CE RoHS
MiBRX-SC-PD	MiBRX Portable Downloader	CE RoHS

Accessories

Accessories for communication	
AC-USB-RS485-02 (Program downloading cable - USB to 2 pin open wire)	
Power Supplies	
RP-2M-1.1A-24VDC-CE-RoHS	
RPS60-24-CE-RoHS	
RPS120-24-CE-RoHS	
RPS240-24-CE-RoHS	
Window - Based software for ladder programming - www.selec.com/software	
Relay modules	
1) RLYMD-1-S4-1CO-24VDC	: 4 Channel 1 change over relay module
2) RLYMD-1-S4-2CO-24VDC	: 4 Channel 2 change over relay module
3) RLYMD-2-S8-1CO-24VDC	: 8 Channel 1 change over relay module
4) RLYMD-2-S8-2CO-24VDC	: 8 Channel 2 change over relay module
5) ERLYMD-2-1-S8-1CO-24VDC	: 8 Channel 1 change over communication based relay module